

CAD FILE:

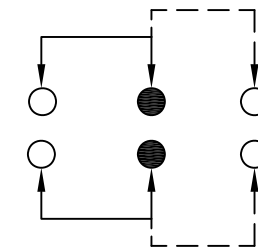

SCHEMATIC (NON-SHORTING)

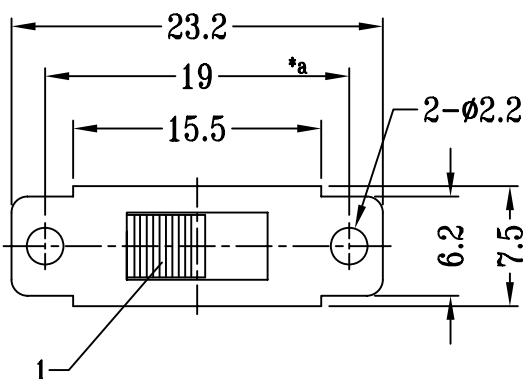
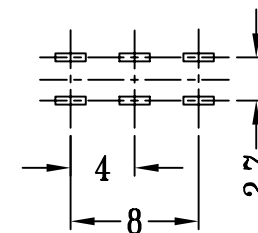
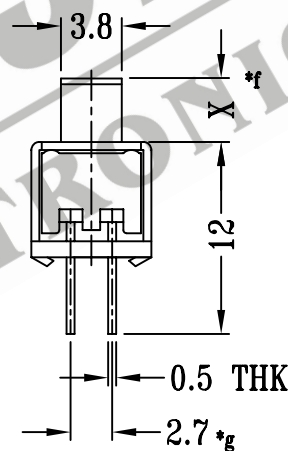
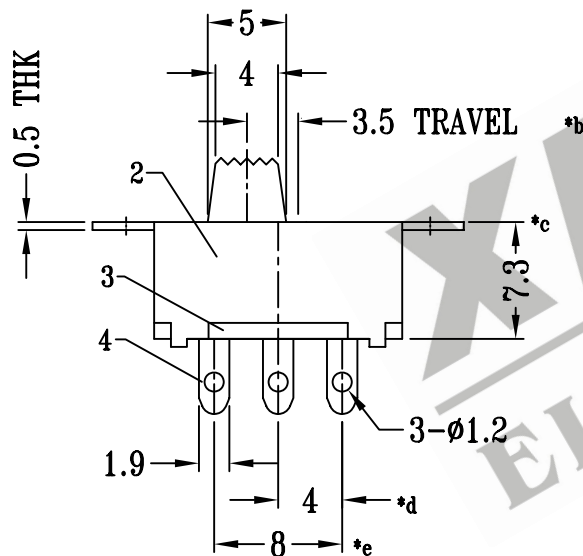

P.C.B LAYOUT

注:带"*"表示关键尺寸(7个)

8					TOLERANCE UNLESS SPECIFIED	SHENZHEN XIEJIA ELECTRONICS CO.,LTD.				
7										
6	SPRING	STEEL WIRE	2	TEMPER	WITHIN: 1.5±0.1mm	ISSUE	DATE	DESCRIPTIONS		APPD.
5	CONTACT CLIP	COPPER STRIP	2	Ag PLATED	OVER : 1.5±0.2mm					
4	TERMINAL	BRASS STRIP	6	Ag PLATED OVER Ni PLATED	TITLE : VERTICAL SLIDE SWITCH		UNIT : MM	DRWG NO.: XJ-DR-SS22G32-00		
3	TERMINAL BASE	PHENOLIC RESIN	1	ORANGE	MODEL: SS-22G32		SCALE: 2 : 1	DWN.	ZHOUYU	2004-9-6
2	FRAME	STEEL STRIP	1	Zn PLATED				CHK'D	FANGYING	2004-9-6
1	KNOB	POM	1	BLACK	ALL MATERIALS MUST BE COMPLIANT TO ROHS		APPD.	KANGXINAN	2004-9-6	
NO.	PART NAME	MATERIAL	Q'TY	FINISHING						